

Solutions for Warehouse & Material handling

Intralogistics



MARKETS &
APPLICATIONS



Warehouse & Material handling

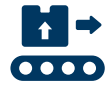

We have the right solutions for all your Intralogistics needs

More than ever, intralogistics are at the heart of today's world. From automatic storage systems to warehouse vehicles, all these machines play a key role in the smooth flow of materials.

With years of experience in integrating systems and designing complete solutions for specific applications, Bonfiglioli can provide the right product to support its customers' growth in materials transport, transportation and storage technology. Efficiency, reliability, flexibility, loading capability and environmental compatibility are the pillars of the Bonfiglioli product line.

Bonfiglioli also provides solutions for:



ACCESS & AERIAL PLATFORMS



LOGISTICS & INDUSTRIAL CRANES



PACKAGING PROCESSES

www.bonfiglioli.com



Warehouse & Material handling

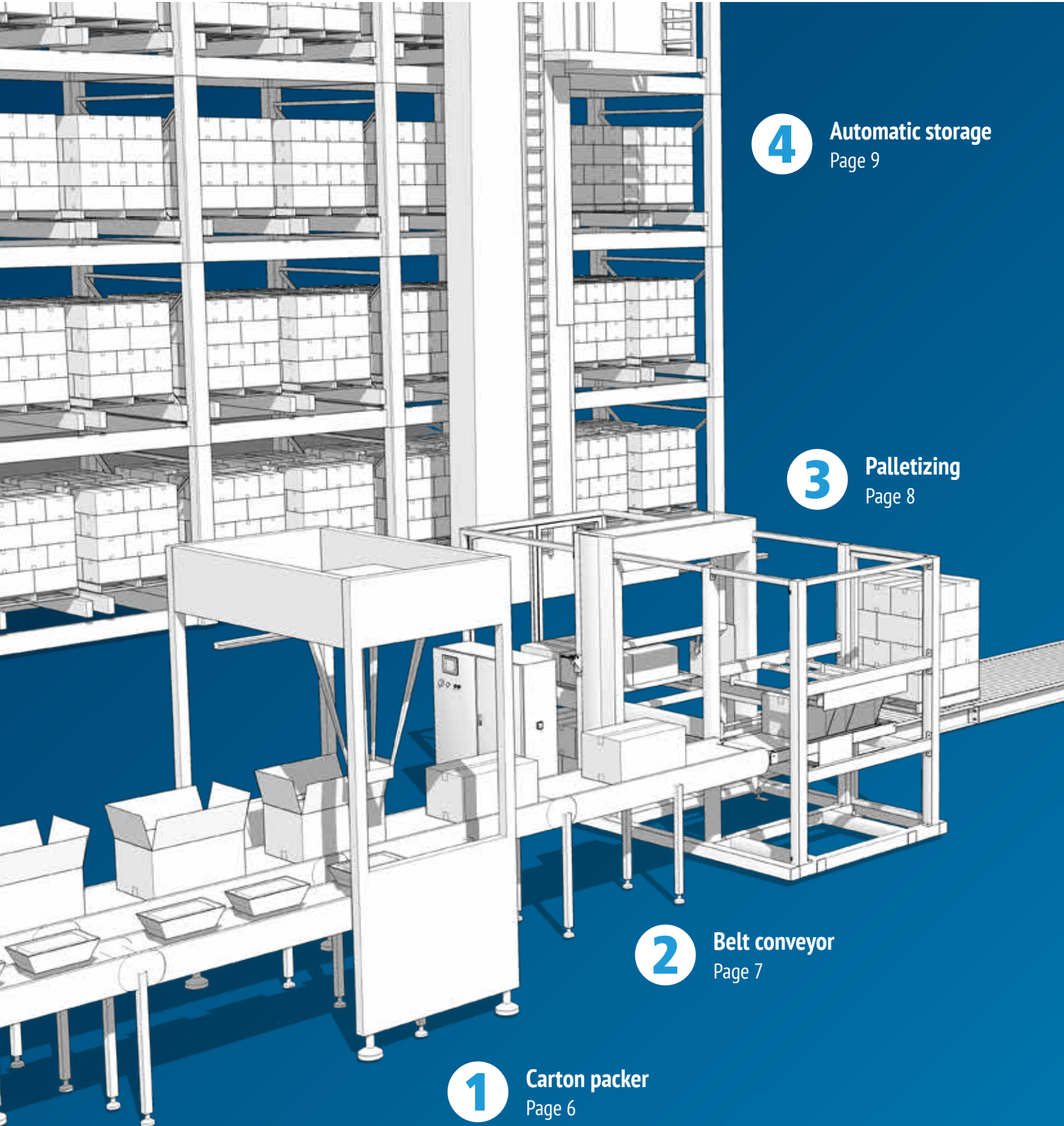

4

Automatic storage
Page 9

3

Palletizing
Page 8

2

Belt conveyor
Page 7

1

Carton packer
Page 6

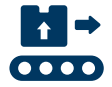

Wrapping
Page 11

6

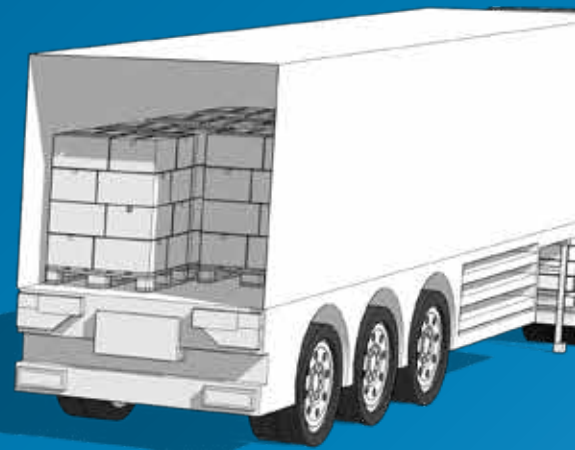
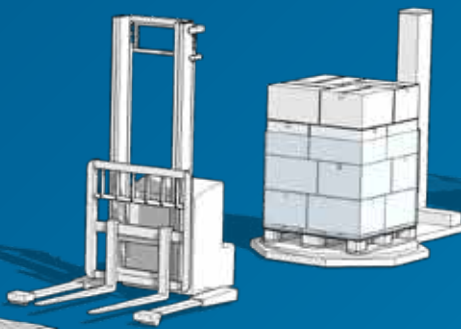

5 **Reach trucks**
Page 10

7 **Forklifts**
Page 12

Warehouse & Material handling

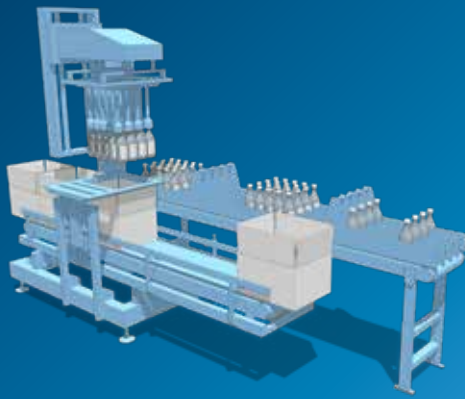

1

Carton packer

Bonfiglioli knows the challenges of these applications and provides solutions to meet them all. From maximally space-saving precision gearboxes to inverters, our customers can rely on Bonfiglioli as full line supplier.

TQ+BMD Series Servo gear units

Benefits

- High precision and dynamic
- Highly compact
- High stiffness
- Designed for continuous and intermittent duty

Features

- Different feedback systems available
- Brake option
- Inertia flywheel
- Customized windings on request

A+BMD Series Servo gear units

Benefits

- Compact
- Universal mounting
- Modular design

Features

- Keyed hollow shaft (metric and inch series)
- Super premium efficiency motors (IE4)
- Wide range of feedback devices
- Brake option
- Inertia flywheel
- Customized windings on request

Active Cube Series Premium Inverter

Benefits

- Interpolated operating mode
- Smooth start
- Torque control

Features

- Ethernet based drive
- Wide power range and parallel connection option to reach up to 1200 kW
- Integrated torque off safety function, external 24 Vd control power supply
- Tropicalization option
- Integrated PLC function with graphic development environment



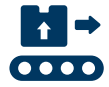

2

Belt conveyor

Belt conveyors are key elements that drive the packaging process from beginning to end. Our drives provide smooth, quiet operations and, thanks to our inverters, our solutions provide unsurpassed control of conveyor speed and motion.

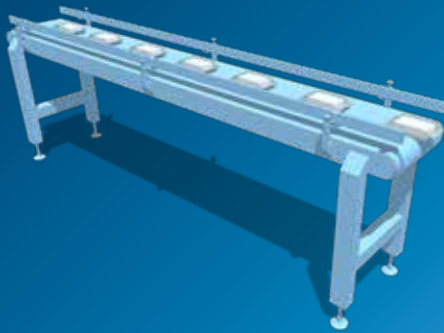

A Series Bevel-helical gearmotors

Benefits

- Compact
- Universal mounting
- Modular design

Features

- Keyed hollow shaft (metric and inch series)
- High and premium efficiency motors (IE2, IE3)
- Wide range of feedback devices (incremental and absolute encoders)

C Series Helical gearmotors

Benefits

- Top torque density
- Highly compact
- Wide speed choice

Features

- Wide choice of output bolt-on-flanges
- Special seals set for severe environment applications
- Surface protection class C3, C4 and C5 (according to UNI EN ISO 12944-2 standard)

VF-W Series Worm gearmotors

Benefits

- Cost effective
- Uncompromising quality
- Specially designed for food & beverage industries

Features

- High and premium efficiency motors (IE2, IE3)



Warehouse & Material handling

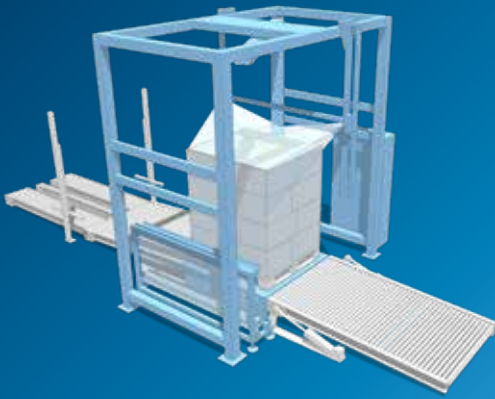

3

Palletizing

Bonfiglioli knows the challenges of these applications and provides solutions to meet them all. From maximally space-saving precision gearboxes to inverters, our customers can rely on Bonfiglioli as full line supplier.

TQ+BMD Series

Servo gear units

Benefits

- High precision and dynamic
- Highly compact
- High stiffness
- Designed for continuous and intermittent duty

Features

- Different feedback systems available
- Brake option
- Inertia flywheel
- Customized windings on request

F Series

Helical gearmotors

Benefits

- Easy installation
- Low noise
- High torque capability

Features

- Keyed Hollow Shaft - Two Bore Options per Size, Keyless Shrink Disc Fitting (Metric series)
- Keyed Hollow Shaft (Inch series)
- Back stops device
- High and premium efficiency motors (IE2, IE3)

Active Cube Series

Premium Inverter

Benefits

- Interpolated operating mode
- Smooth start
- Torque control

Features

- Ethernet based drive
- Wide power range and parallel connection option to reach up to 1200 kW
- Integrated torque off safety function, external 24 Vd control power supply
- Tropicalization option
- Integrated PLC function with graphic development environment



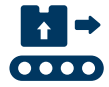

4

Automatic storage

We provide our customers with complete solutions for the highest possible precision, efficiency and energy optimization for automatic storage applications. From the inverter to the drives, Bonfiglioli is a one-stop company that understands today's market challenges.

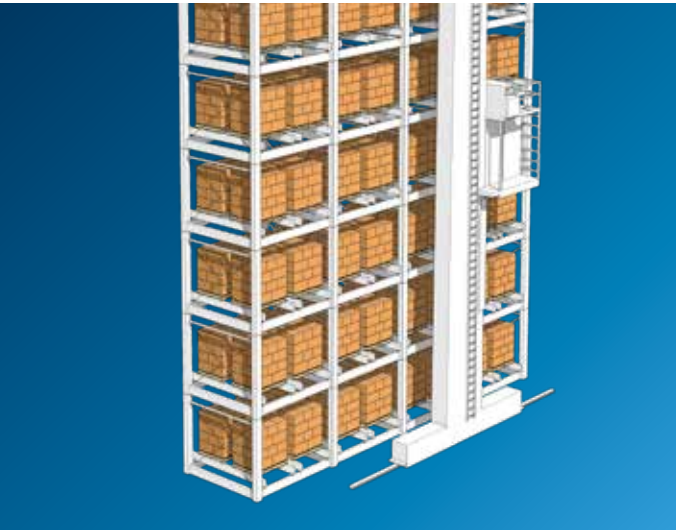

A+BMD Series Servo gear units

Benefits

- Compact
- Universal mounting
- Modular design

Features

- Keyed hollow shaft (metric and inch series)
- Super premium efficiency motors (IE4)
- Wide range of feedback devices
- Brake option
- Inertia flywheel
- Customized windings on request



Active Cube Series Premium Inverter

Benefits

- Interpolated operating mode
- Smooth start
- Torque control

Features

- Ethernet based drive
- Wide power range and parallel connection option to reach up to 1200 kW
- Integrated torque off safety function, external 24 Vd control power supply
- Tropicalization option
- Integrated PLC function with graphic development environment



Warehouse & Material handling



5

Reach trucks

Steerable drives

High maneuverability in tight spaces is one of the major challenges that stackers face in a warehouse. Our solutions allow the machine to operate in small vertical locations, and include the benefits of noise reduction and low maintenance cost.

EL Series

Electric wheel drives

Standard features and benefits

- High maneuverability
- Two-stage helical & bevel gearboxes
- Manual steer and power steer versions
- Optimized gear design for efficiency and noise
- Integrated low voltage electric motor and parking brake
- Complete system with tyres

Optional features available on request

- Cold environment versions
- Integrated tiller or castor wheel supports



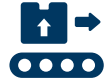

6

Wrapping

Last but not least, the tertiary phase includes both palletizing and wrapping machines to prepare the product for shipment. We provide solutions that can handle high speeds and precise movement, while stabilizing and properly aligning the material.

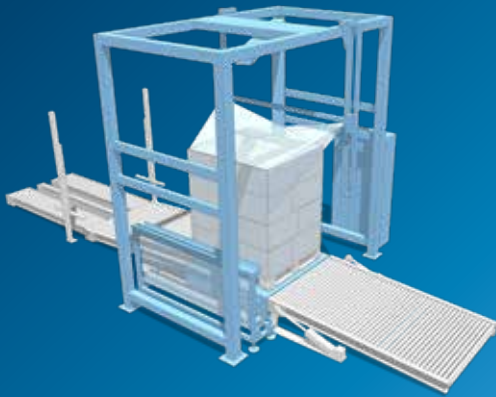

VF-W Series Worm gearmotors

Benefits

- Cost effective
- Uncompromising quality
- Specially designed for food & beverage industries

Features

- High and premium efficiency motors (IE2, IE3)

A Series Bevel-helical gearmotors

Benefits

- Compact
- Universal mounting
- Modular design

Features

- Keyed hollow shaft (metric and inch series)
- High and premium efficiency motors (IE2, IE3)
- Wide range of feedback devices (incremental and absolute encoders)

Agile Series Standard inverter

Benefits

- Smooth start
- Feed roll control
- Low energy consumption

Features

- Sensor-less vector control for asynchronous and synchronous motors
- Integrated torque off safety function
- Integrated Modbus
- Optional communication card (Profibus, CanOpen...)



Warehouse & Material handling



Forklifts

7

Traction systems

Bonfiglioli supplies efficient, low-noise solutions with integrated, high-performance electric motors and low-maintenance brake systems for forklifts. With reduced energy consumption through longer battery life, and easy maneuverability, our products meet this typical application's requirements.

Idle steering system

For decades, Bonfiglioli has been providing the right solutions for forklift idle steering systems, lending the machine smooth operation and easy maneuverability in narrow aisles.

600F Series

Electric powertrains

Standard features and benefits

- Dual planetary gearbox
- Optimised gear design for maximum efficiency and minimum noise
- Wet disc service brake with low displacement actuation
- Parking brake with mechanical lever actuation
- Integrated, customised mast support
- Integrated AC traction motor in IP20 or IP43 protection ratings
- Integrated, high accuracy, silicon based KTY temperature sensor
- Integrated, high resolution hall effect speed sensor

Optional features available on request

- Spring-applied hydraulic release parking brake
- Mechanical disengagement for towing, with no need to remove the wheel and without oil drop

600WOC Series

Idle steering System

Standard features

- Hydraulic steering
- Optimised design for steering angle

Optional features available on request

- Electric steering for 3-wheel, also with inverter
- Anti-vibration parts
- Potentiometer for steering angle



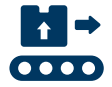

Global Presence



With a broad and extensive presence in 22 countries and 5 continents, Bonfiglioli is one of the international market leaders. Our organization makes the most of geographic proximity to offer complete solutions combining efficiency and competence.



3700
EMPLOYEES



20
BRANCHES



14
PLANTS



550
DISTRIBUTORS



80
COUNTRIES

We Are a Global Company

Thanks to an international network of sales branches and closely interconnecting production plants, we can guarantee the same high standards of Bonfiglioli quality anywhere at any given time. Aware that our direct presence in local markets is the key to long-lasting success, our family includes 20 sales branches, 14 production plants and more than 500 distributors around the world.

Our organization is always close by, offering complete and efficient solutions and supporting our customers with dedicated services, such as co-engineering or after-sales assistance.



Bonfiglioli Worldwide Locations

Australia

Bonfiglioli Transmission (Aust.) Pty Ltd.

2, Cox Place Glendenning NSW 2761
Locked Bag 1000 Plumpton NSW 2761
Tel. +61 2 8811 8000

Brazil

Bonfiglioli Redutores do Brasil Ltda.

Travessa Cláudio Armando 171 - Bloco 3 - CEP 09861-730
Bairro Assunção - São Bernardo do Campo - São Paulo
Tel. +55 11 4344 2322

China

Bonfiglioli Drives (Shanghai) Co. Ltd.

#68, Hui-Lian Road, QingPu District,
201707 Shanghai
Tel. +86 21 6700 2000

France

Bonfiglioli Transmission s.a.

14 Rue Eugène Pottier
Zone Industrielle de Moimont II - 95670 Marly la Ville
Tel. +33 1 34474510

Germany

Bonfiglioli Deutschland GmbH

Sperberweg 12 - 41468 Neuss
Tel. +49 0 2131 2988 0

Bonfiglioli Vectron GmbH

Europark Fichtenhain B6 - 47807 Krefeld
Tel. +49 0 2151 8396 0

O&K Antriebstechnik GmbH

Ruhrallee 8-12 - 45525 Hattingen
Tel. +49 0 2324 2050 1

India

Bonfiglioli Transmission Pvt Ltd.

Plot No. AC7-AC11, SIDCO Industrial Estate,
Thirumudivakkam - 600 044 Chennai
Tel. +91 44 2478 1035

Industrial

Survey No. 528, Porambakkam High Road,
Mannur Village, Sriperambudur Taluk - 602 105 Chennai
Tel. +91 44 6710 3800
Plot No. A-95, Phase IV, MIDC Chakan, Village Nighoje
Pune, Maharashtra - 410 501

Italy

Bonfiglioli Riduttori S.p.A.

Headquarters

Via Giovanni XXIII, 7/A - 40012 Lippo di Calderara di Reno
Tel. +39 051 647 3111

Mobile, Wind

Via Enrico Mattei, 12 Z.I. Villa Selva - 47100 Forlì
Tel. +39 0543 789111

Industrial

Via Bazzane, 33/A - 40012 Calderara di Reno
Tel. +39 051 6473111
Via Trinità, 1 - 41058 Vignola
Tel. +39 059 768511

Bonfiglioli Italia S.p.A

Via Sandro Pertini lotto 7b - 20080 Carpiano
Tel. +39 02 985081

Bonfiglioli Mechatronic Research S.p.A

Via Unione 49 - 38068 Rovereto
Tel. +39 0464 443435/36

New Zealand

Bonfiglioli Transmission (Aust.) Pty Ltd.

88 Hastie Avenue, Mangere Bridge, 2022 Auckland
PO Box 11795, Ellerslie
Tel. +64 09 634 6441

Singapore

Bonfiglioli South East Asia Pte Ltd.

8 Boon Lay Way, #04-09,
8@ Tadehub 21, Singapore 609964
Tel. +65 6268 9869

Slovakia

Bonfiglioli Slovakia s.r.o.

Robotnícka 2129
Považská Bystrica, 01701 Slovakia
Tel. +421 42 430 75 64

South Africa

Bonfiglioli South Africa Pty Ltd.

17 Heron Park, 80 Corobrik Road, Riverhorse Valley
Durban 4017
Tel. +27 11 608 2030

Spain

Tecnotrans Bonfiglioli, S.A.

Pol. Ind. Zona Franca, Sector C, Calle F, nº 6
08040 Barcelona
Tel. +34 93 447 84 00

Turkey

Bonfiglioli Turkey Jsc

Atatürk Organize Sanayi Bölgesi, 10007 Sk. No. 30
Atatürk Organize Sanayi Bölgesi, 35620 Çiğli - Izmir
Tel. +90 0 232 328 22 77

United Kingdom

Bonfiglioli UK Ltd.

Unit 1 Calver Quay, Calver Road, Winwick
Warrington, Cheshire - WA2 8UD
Tel. +44 1925 852667

USA

Bonfiglioli USA Inc.

3541 Hargrave Drive
Hebron, Kentucky 41048
Tel. +1 859 334 3333

Vietnam

Bonfiglioli Vietnam Ltd.

Lot C-9D-CN My Phuoc Industrial Park 3
Ben Cat - Binh Duong Province
Tel. +84 650 3577411



We have a relentless commitment to excellence, innovation and sustainability. Our team creates, distributes and services world-class power transmission and drive solutions to keep the world in motion.

HEADQUARTERS

Bonfiglioli Riduttori S.p.A.
Via Giovanni XXIII, 7/A
40012 Lippo di Calderara di Reno
Bologna (Italy)
tel: +39 051 647 3111
fax: +39 051 647 3126
bonfiglioli@bonfiglioli.com
www.bonfiglioli.com

